

RECOMMENDED PCB LAYOUT
GENERAL TOLERANCE ±0.05

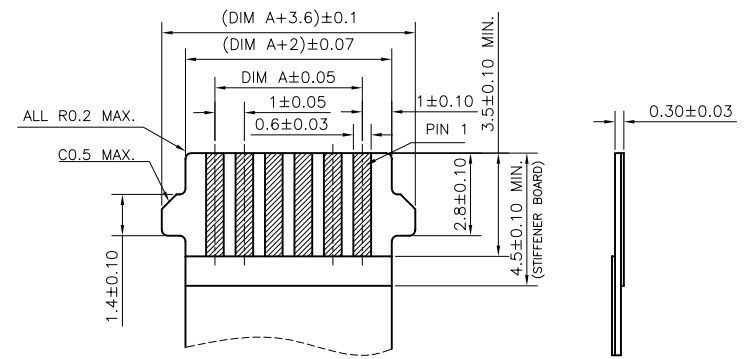
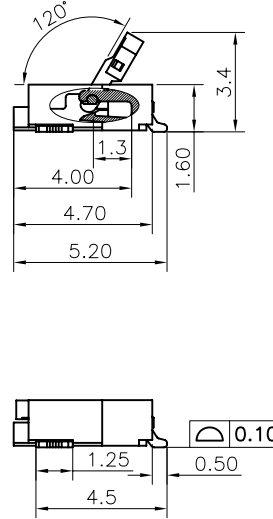
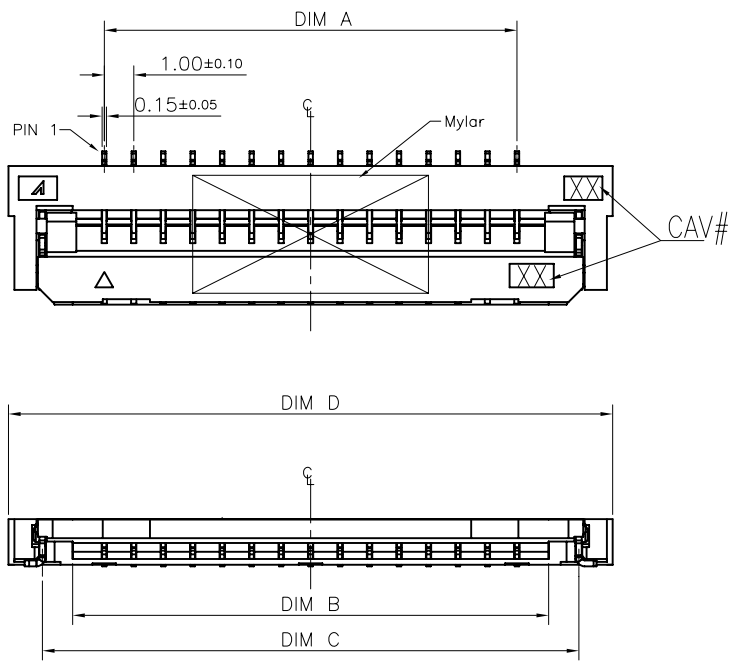

RECOMMENDED FPC/FFC DIMENSIONS
GENERAL TOLERANCE ±0.05

NOTES:

- MATERIAL:
 - HOUSING: MATERIAL IS LCP GF40%, UL 94 V-0
 - ACTUATOR: MATERIAL IS NYLON-6T GF30%, UL 94 V-0
 - CONTACT: COPPER ALLOY
 - FITTING NAIL: COPPER ALLOY
- FINISH:
 - CONTACT:
 - GOLD FLASH ON CONTACT AREA.
 - 50~100u" NICKEL UNDERPLATING OVERALL.
 - FITTING NAIL:
 - 80u" MIN MATT TIN PLATING ON SOLDER TAILS.
 - 50u" MIN NICKEL UNDERPLATING OVERALL.
- REFLOW SOLDER CAPABLE TO 260°C PER ACES SPEC.
- SPEC. PLS. REFER TO PS-51503-xxxx-xxx
- PACKAGE PLS. REFER TO 51586-XXXX-XX-TRP
- PART NUMBER

51586-XXX X X-XXX		XXX	HOUSING MATERIAL&COLOR	ACTUATOR MATERIAL&COLOR
NO OF CKT		001	HALOGEN FREE PLASTIC & BLACK	HALOGEN FREE PLASTIC & NATURAL
PACKING		PLATING		
0: TAPE & REEL		1: GOLD FLASH(LEAD FREE)		
4: TAPE & REEL WITH MYLAR				

CKT	DIM A	DIM B	DIM C	DIM D	DIM E
28	27.00	29.15	31.2	33.5	30.6
32	31.00	33.15	35.2	37.5	34.6

一般公差 TOLERANCES X ±0.5 XX ±0.15 X ±0.25 XXX ±0.1 ANGLES ±2°		宏致電子股份有限公司 Aces Electronics Co.,Ltd.			
檢驗尺寸標示 SYMBOLS Ⓢ Ⓣ INDICATE CLASSIFICATION DIMENSION Ⓢ MARK IS CRITICAL DIM. Ⓣ MARK IS MAJOR DIM.	品名 (TITLE) 1.0mm FPC EASY ON CONN. SMT R/A TYPE	製圖 (DR) 14/05/12 審核 (CHKD) BRAVE	圖號 (DWG NO.) 51586-XXXX-XXX 核准 (APPD) SIMON		
表面處理 (FINISH)	比例 (SCALE) 4:1	單位 (UNITS) mm		張數 (SHEET) 1 OF 1	SIZE A4 REV A

A

B

C

D

E

F